

目 录

Content

1、安全说明	2
General safety instructions	
2、产品介绍	2
Product instructions	
3、安装调试	4
Installation and trial-run	
4、控制面板使用说明	7
Control panel Instruction	
5、一般故障处理	10
Common faults and treatment	
6、作业环境要求	11
Environment requirements	
7、保修服务	11
Warranty service	
8、装箱单	12
Packing list	

一、安全说明： **General Safety Instruction**

- 1.电机接通电源时请不要把脚放在脚踏板上
Do not place your foot onto the pedal when connecting to the power source
- 2.本产品需专业人员安装，调试
Installation and trial-run must be done by skilled person
- 3.严禁在通电时打开控制箱与电机端盖
Open control box or motor cover under electrical power is not permitted
- 4.必须保证系统接地可靠
Make sure the earthing system is working well
- 5.以下操作请务必断电
When doing the following the machine has to be disconnected from the power supply
 - A.换针、穿线或更换底线时
When threading machine, replacing needle, bottom thread
 - B.安装、拆卸或修理时
When install, dismantle and repair
 - C.翻抬缝纫机时
When turn over the sewing machine

二、作业环境要求： **Environmental Requirements**

- 1.请不要在过潮湿的环境中作业
Please do not work at damp place
- 2.用户供电应保持稳定 210V~240V
The voltage requires being stable (210V~240V)
- 3.用户使用前必须接地，确保人身安全
Must be adequately grounded for safety
- 4.不要在过热地方作业
Do not work at high temperature
- 5.控制系统与电机不要在强磁高辐射环境中作业，以免干扰而使系统错误

Do not run motor and control system near to ferromagnetic or high-radiance area

三、产品介绍： **Product instruction**

本产品由本公司自主研发，产品个性鲜明，真正体现出了机电一体化概念，更是节能、高效、环保、优美集结于一身。可广泛适用于多种缝纫设备。

This product by the company independent research and development, distinct personality, truly reflects the concept of mechanical and electrical integration, more energy saving, high efficiency, environmental protection, beautiful assembled in one. It can be widely applied to a variety of sewing equipment.

1.组成部分： **component**



控制器系统由控制器和电机两部分：

The servomotor is composed of control system and motor

A.控制器：控制箱和速控器。

A. Control system includes control box and speed controller

系统界面连接和操作面板示意图如下：

Introduce for control panel

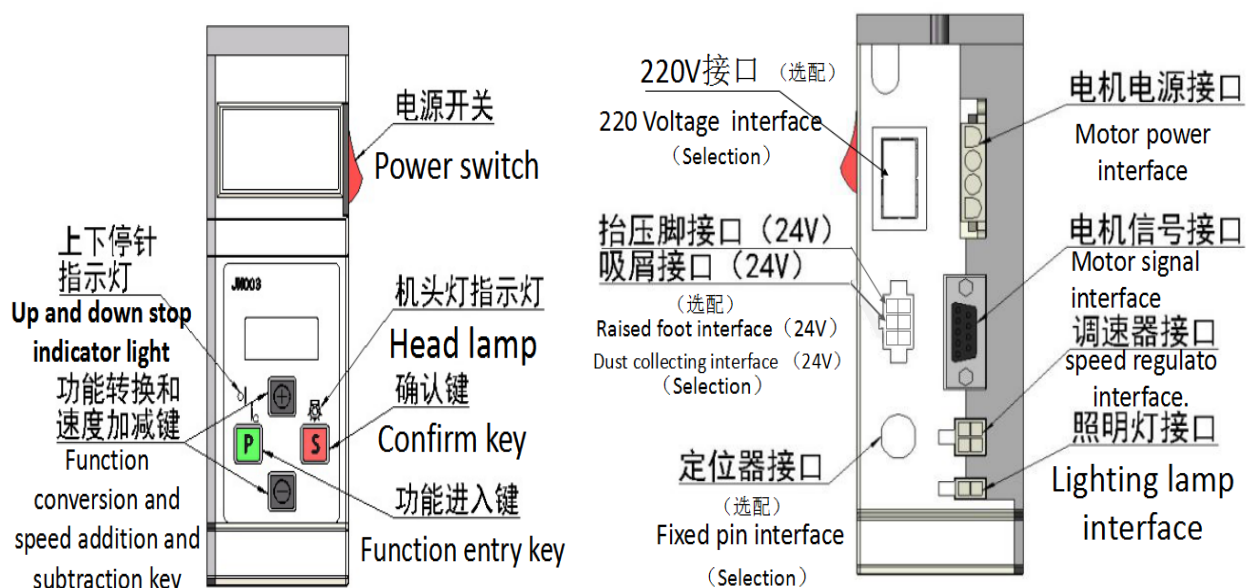

本控制系统体现出了超前的设计理念，系统操作简单易上手，整个控制系统性能优越。具有起步快，停车快、准等优点。而且电路模块保护功能完善：有欠压、过流、等一系列保护功能。速控器可实现无级调速。

This control system features is easy to use and features in excellent performance, including quick start, quick stop (sewing machine), accurate needle position. Furthermore, the modular circuit has Self-Protection System when against lower voltage, over current, over heat etc. speed controller is realized by the pedal speeder.

B.电机： motor

电机转子属于稀土永磁材料，具备功率大，节能环保等各大优点。电机内设有霍尔传感器，使电机具有准确的上下定位，使电机体积更小更美观。

Rotor is made of rare earth permanent magnet, guarantee high power and environmental. Exactly needle UP/DOWN position due to its built-in Hall type sensor and compact design.

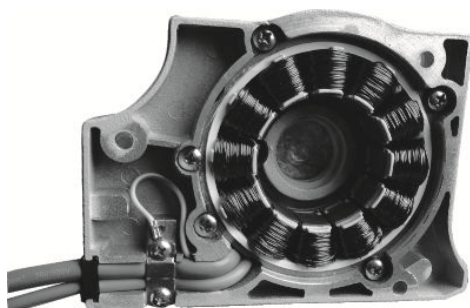

C.部分产品组装效果图： Partial demonstration

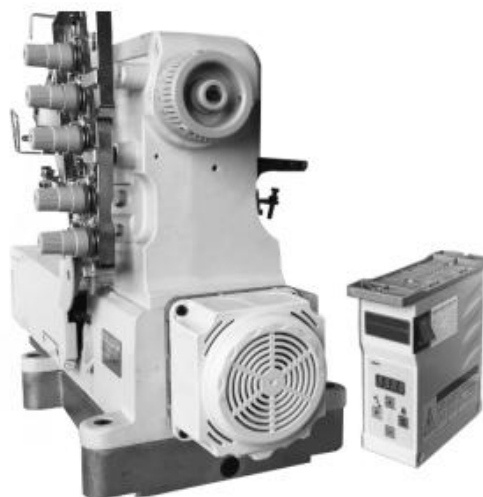

2、性能参数指标 Specifications

电源供电电压	Voltage	220V 两相 2phase
频率	Frequency	50~60HZ
电机转速	Speed	200-6500RPM
电机扭矩	Motor torque	400≤2N.M 500≤3N.M

四、安装调试：（直驱式电机安装方法）

Installation and trial-run（Direct Drive type）

1.控制箱速控器安装如下图

Install control box and speed controller as below figure

将控制箱和速控器用螺钉依次安装在缝纫机台板上。

Using screws, mount the Control Box and speed controller onto sewing table properly.

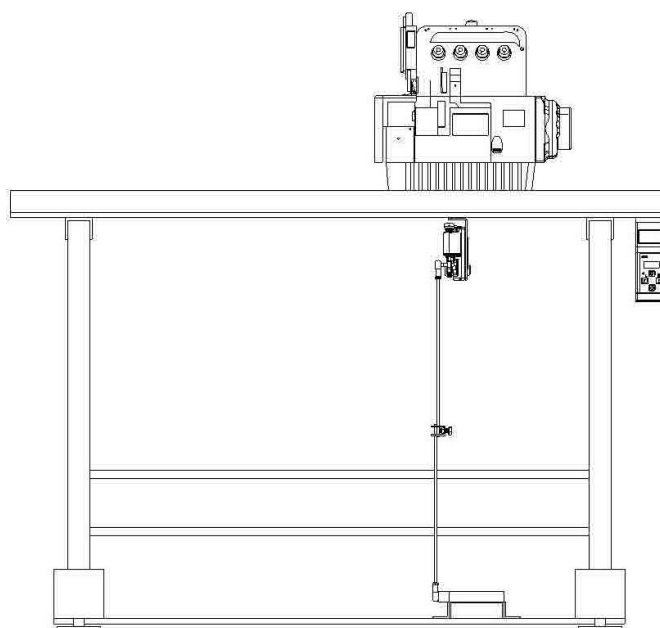

2.直驱电机安装示意图:

Schematic diagram of the installation of direct drive motor

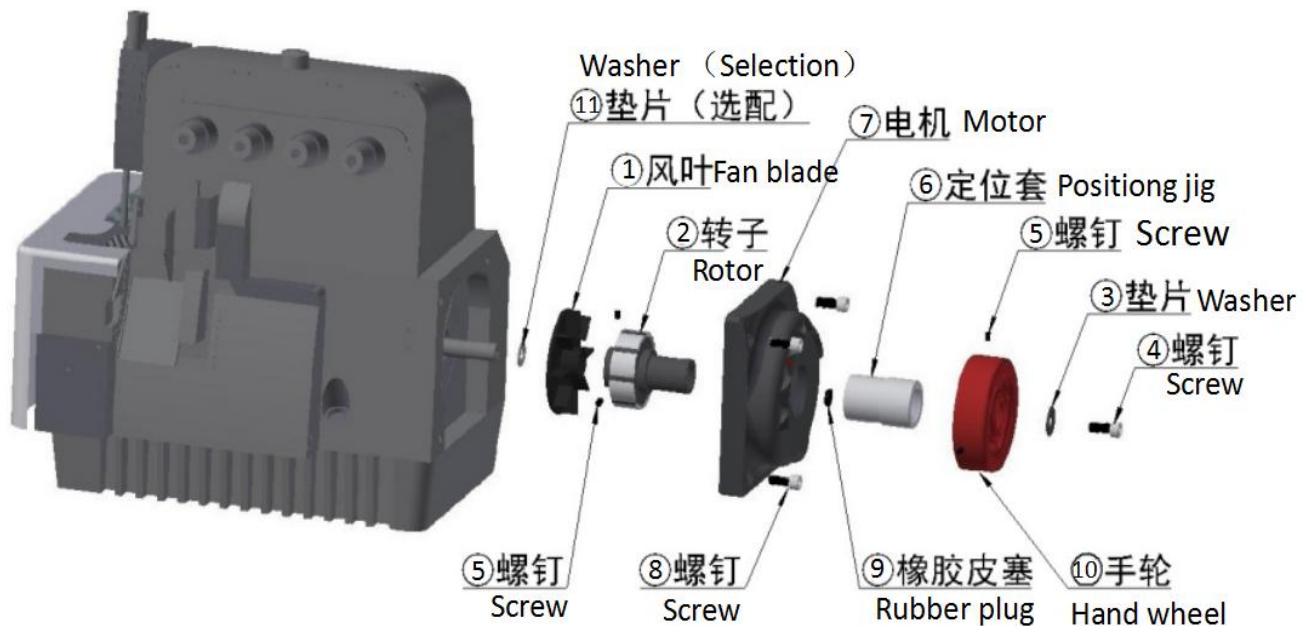

直驱电机安装共 5 步骤： Motor installation of a total of 5 steps

(1) 装转子： Install rotor

A) 拆掉缝纫机上的手轮、皮带罩和风叶。

Remove the hand wheel, belt cover and wind blade on the sewing machine.

B) 将图①风叶和图②转子装入缝纫机轴上，用图③垫片和图④螺钉固定住转子和风叶，再固定图⑤两个螺钉。

检查 1：用右手抓紧转子，左手转动风叶要无自转现象。

检查 2：用手转动缝纫机应无加重。

Figure①fan blade and figure②rotor install into the shaft of sewing machine in the picture, fixed rotor and fan with figure③gasket and figure④screw, then fix figure⑤two screws.

Check 1: Clutch rotor with right hand, the left hand turns the fan to have no rotation.

Check 2: Hand rotation of the sewing machine should not increase heavy.

(2) 装电机：用专用塑料定位套图⑥卡在电机图⑦孔 $\Phi 30$ 内，对准图②转子装入缝纫机，用图⑧螺钉固定，螺钉拧紧后要能轻松拔出定位套。（注：定子装入转子要注意磁铁吸力，小心夹到手。）

Install motor: Using a special plastic locating figure⑥card in the motor map positioning hole whose diameter⑦ is 30, install into sewing machine directed at figure②rotor, then fixed with figure⑧screws, screw down to be able to easily pull out the positioning sleeve.(Notes: The stator into the rotor should pay attention to the magnet suction, carefully clip hand .)

(3) 检查转子和定子是否装好

Check the rotor and the stator is installed

A) 拿出图⑨橡胶孔塞。

Taking out figure⑨rubber hole stopper.

B) 目测转子平面与定子平面是否相平，两面相平度不得超过 1.5mm (看剖视图 A), 如果超过 1.5mm 的话, 要拆掉电机和转子用图⑪垫片来调整。

Check the plane of the rotor and the stator is flat or not, two surface roughness shall not exceed 1.5mm(See section view A), if more than 1.5mm, to remove the motor and the rotor with figure⑪gasket to adjust



图 A

C) 调整好后装回橡胶孔塞。(注: 电机两平面装的越平越好, 如果两平面超过 1.5mm 的情况下, 电机比正常安装的发热量大和力矩减小现象。)

Adjusted to fit back rubber hole stopper.(Notes: The distance between two flat as small as possible, if more than 1.5mm, motor

will be calorific value more and torque decreases.)

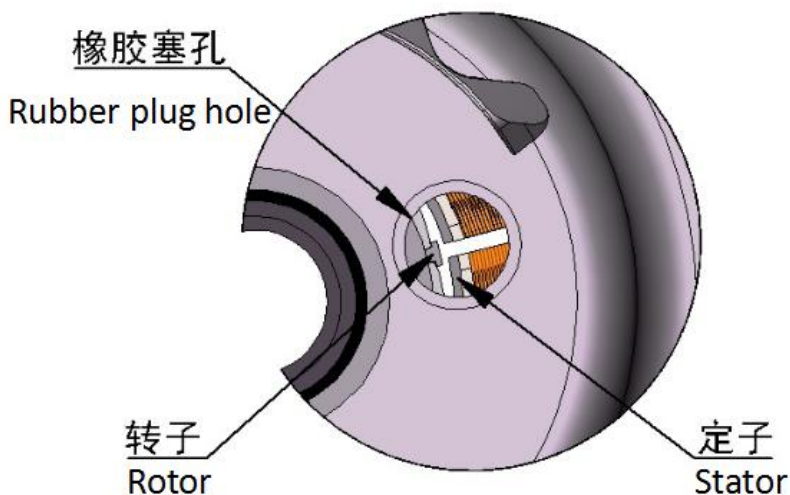
(4) 装手轮: Install hand wheel

A) 用手转动缝纫机，使机针停在最高位

Turn the sewing by hand , make the needle stop at the highest level

B) 将手轮装入转子并将刻度 5 字对准电机外壳的刻度线（看图 B），（注：飞马款 EX、MX 和大和款包缝机的电机要对准 3 个小条上（看图 D）。拧紧安装示意图上的图⑤ 2 个螺钉，并且保证手轮与电机外壳留有 1.5mm--2.5mm 的间隙（看图 C）。）

Put the hand wheel in the rotor, and mark the calibration line of the motor housing with the scale 5 (As Pic.B). Tighten two screws of figure ⑤, and keep the clearance of hand wheel and motor 1.5mm~2.5mm (As Pic.C).(Notes: The motor of FEIMA EX, MX and DAHE overlock machine need aim three little strips (As Pic.D).)

(5) 检查: 手转动手轮无卡擦现象，缝纫机也无加重。

Check: Hand wheel hand wheel without card wiping phenomenon, Sewing machine weight does not increase



图 B

图 C

图 D

五、控制面板使用说明 Installation for Control Panel

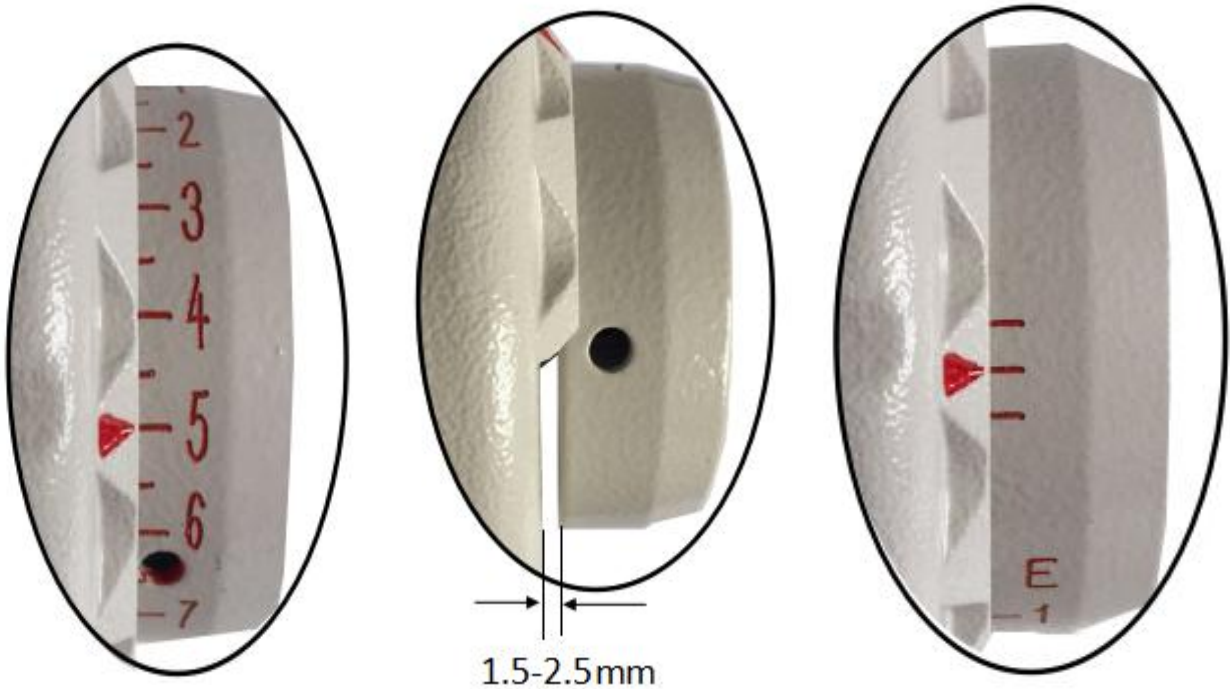
各按键的用途： Each key purpose:

(1) “P” 键的用途:

Function of “P” key:

第一：“P”键为上、下停针键，按下“P”键，上灯孔亮，为上停针；下灯孔亮，为下停针；两个灯孔都不亮，为自由停针；

First: ”P” key for upper and lower stop needle position. Press “P”,if up pinhole lamp lights means it’s up stop needle, if down pinhole lamp lights means that it is down stop needle , if two lamps off means needle position is freedom.

第二：功能进入键（见进入参数的操作方法）

Second: Function Enter button (below to enter the parameter method of operation)

(2) “S” 键的用途:

Function of “S” key:

第一：“S”键为机头灯开关键，按下“S”键，当“S”键上的小灯亮为打开机头灯，灭为关掉机头灯。

First : “S” button for off or on the head lamp.Press “S” key the lamp lights , if don’t do it is turn off.

第二：功能参数（确认）键（见进入参数的操作方法）

Second: Function Enter button (below to enter the parameter method of operation)

(3) “+” “-” 键的用途:

Function of “+” 、 “-” key

此两个键用于转速调整和参数调整。

These two keys are used to adjust speed and parameter modulation.

2.进入参数的操作方法

例：怎样把电机的顺时针转调到逆时针转：

第一步：打开电源；

第二步：先按“P”键不放，同时按“+”号键，此时画面会显示 P-00。

第三步：按“+”号键，把 P-00 调至 P-02，（P-02）就是电机正反转参数（常用参数表上有标明）；

第四步：按下“P”键画面会显示“1”；

第五步：按下“-”号键把“1”调到“0”（“1”为顺时针转，“0”为逆时针转，常用参数表上有标明）；

第六步：按下“S”键确定参数调整完成。

2. To enter the parameter method of operation:

Example: How to change the motor from clockwise to counterclockwise:

Step one: Open the power;

Step two: Press the "P" key, no leave, and press "+" key, the screen will display the P-00;

Step third: Press "+" key, change the P-00 to P-02, (P-02) is a motor clockwise or counterclockwise parameters (common parameter list has record);

Step four: Now press "P" key (enter into parameters) screen will display "1";

Step fifth: Press "-" key, change "1" to "0"; ("1" for clockwise, "0" for the counter clockwise rotation, commonly used in the parameter table is indicated);

Step six: Press the "S" key to determine the parameters, save and exit the parameter.

3. 恢复出厂设置

恢复出厂设置方法：先按“P”键不放，同时按“+”号键，此时画面会显示 P-00，再长按“S”键约 3 秒即可。

3. Restore factory settings

Restore factory settings: Press the "P" key, no leave, and press the "+" key, the screen will display the P-00, then press "S" key 3 seconds.

4. 电机常用参数设置 Commonly used parameter setting

序号 The serial number	参数编号 Parameters name	参数名称 The parameters name	参数范围 Adjusting rang		出厂设置 The factory reset settings	备注
1	P-01	最大速度锁定 Maximum Speed lock	200-6500RPM		4500 转	
2	P-02	电机方向 Direction of rotation	0 是逆时针 0 is reverse turn needle	1 是顺时针 1 is clockwise turn	1	老款平缝电机调到 2 或 3 Old flat seam motor change to 2

					or 3
3	P-03	下停角度 The needle angle	6-18°	12°	
4	P-04	起缝速度 Start sewing speed	200-800 转	250 转	
5	P-05	加速快慢 Speed up And slow	2000-4000 转	3500 转	
6	P-06	定针缝 Set the seam	0-999 针	0	
7	P-07				
8	P-08				
9	P-09				
10	P-10	自动间隙运行 (跑合) Automatic Clearance run(run)	把 0 改成 1 再按 S 键 Press the S key when change 0 to 1	0	
11	P-11	抬压脚起动时间 Presser foot ascend starting time	0-2000ms	0	
12	P-12	抬压脚保护时间 Ascension presser foot protection time	1-120s	4s	
13	P-13	老款平车电机选择 Old section flat sewing machine selection	1 是老款平缝机电机 Motor option 1 is old section flat sewing machine	0	0 是普通机 0 is ordinary sewing machine
14	P-14	最大电流限制 Maximum current limiting	50-1000	280	
15	P-15	是否检测上针位 Whether to detect the up needle position	1:检测针位, 0:不检测 1:detecting needle 0:no detection	1	

六、 一般故障处理： Common faults and treatments

序号 The serial number	错误码 Error code	错误内容 Error content	错误问题的多种可能 Several possible error problem
1	Er01	找不到停针位 Can't find the needle position	1.手轮靠的不够近间隙在 2.5mm 内 2.九针插头接触不良 3.电机霍尔坏，要更换电机 4.手轮上的磁铁掉落 1. The hand wheel is not close, clearance within 2.5 mm 2. Nine plug contact undesirable 3. Motor holzer bad, to replace the motor 4. The hand wheel magnet in the loss
2	Er02	开机没有检测到调速器 Not detected boot speed regulator	1.调速器插头没有插 2.调速器线断了或接触不良 1. Speed control device without plug 2. Speed wire is broken or contact undesirable
3	Er03	电机霍尔或相位线错误 Motor holzer or phase error	1.九针插头接触不良 2.电机没有安装好，参照图 A 3.霍尔坏 1. Nine hole plug contact undesirable 2. The motor doesn't pack good 3. Holzer is bad
4	Er04	堵转保护 Locked-rotor protection	1.电机过载 2.电机与电控相连接的四心线接触不好 3.电机断线或坏了 1. The motor overload 2. The motor and the controller connected four hole line contact is not good 3. Motor is bad
5	Er05	硬件过流保护 Hardware over-current protection	1.电机过载 2.信号线接触不好或断了 3.主板坏了 1. The motor overload 2. Line contact is bad or broken 3. Main board is bad

6	Er07	串口通信超时错误 Serial port communication timeout error	显示屏至主板信号线不良或主板坏 Display to the system board signal is bad or board is bad
7		显示屏无电 开关有电 Screen without electricity Switch with electricity	1.主板坏 Main board is broken 2.显示屏与主板连接线接触不良 The display screen and the main board connection line contact is bad

七、保修服务： Warranty Service

1.本产品自购买起免费保修 2 年，终身维护。保修期内除人为损坏以外出现任何质量问题可免费维修

Since from the purchase of this product,the free 2-year warranty,lifetime maintenance. During the warranty period,any quality problems the product will be free repaired,except artificial damage.

2.在保修期内，以下情况出现损坏本公司不给予保修服务：

In the warranty period, the following circumstances appear to damage the company does not give the warranty service

A. 未经本公司同意自行拆卸、修理、改装造成的故障或损坏。

Dismantle the motor unit without permission and cause damage.

3.但凡出现无法解决的问题可以联系本公司。

Whenever find the problem can not be solved, you can contact with our company

八、装箱单： Packing List

电机定子	Stator	1
电机转子	Rotor	1
手轮	Hand Wheel	1
脚踏板连接杆	Pipe Link	1
内六角螺丝	Hexagon Screw	6
定位护套	Locator Bush	1
风叶	Fan Blade	1
速控器	Speed controller	1
自攻螺丝	Self Tapping Screw	6
说明书	Manual	1
合格证	Quality Certificate	1
电控箱	Electric control box	1